

**MediaClock™
MPEG Clock Generator with VCXO**

Features

- Integrated phase-locked loop (PLL)
- Low jitter, high-accuracy outputs
- VCXO with analog adjust
- 3.3V operation

Benefits

- Highest-performance PLL tailored for multimedia applications
- Meets critical timing requirements in complex system designs
- Large ±150-ppm range, better linearity
- Enables application compatibility

Part Number	Outputs	Input Frequency Range	Output Frequencies
CY24212-1	1	13.5 MHz/27 MHz (selectable)	27 MHz
CY24212-2	2	13.5 MHz/27 MHz (selectable)	Two copies of 27 MHz
CY24212-3	2	27 MHz	27 MHz/27.027 MHz (-1 ppm)
CY24212-5	2	27 MHz	27 MHz/27.027 MHz (0 ppm)

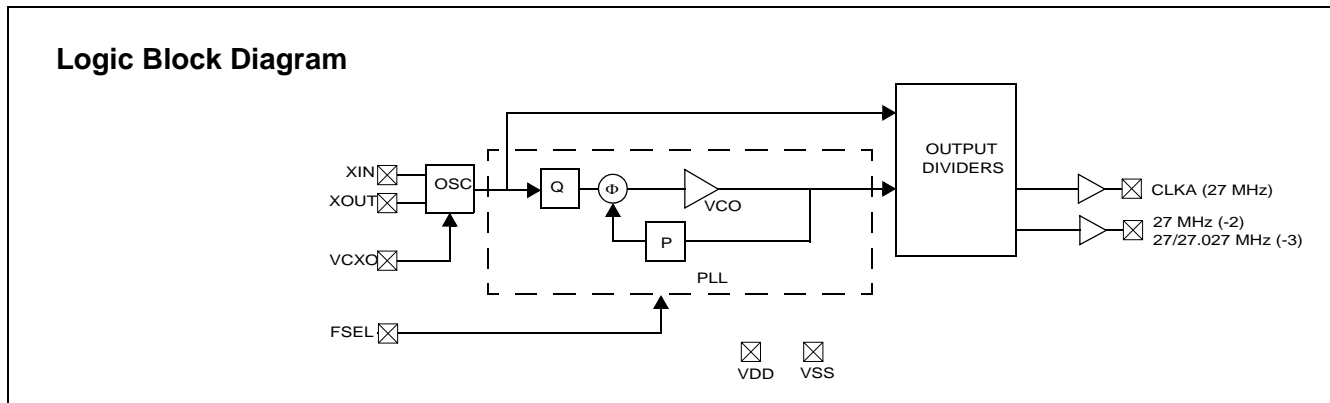

Table 1. CY24212 (-1, -2) Frequency Select Option

FSEL	Reference	CLKA/CLKB
0	13.5 MHz	27 MHz
1	27 MHz	27 MHz

Table 2. CY24212 (-3, -5) Frequency Select Option

FSEL	Reference	CLKA	CLKB
0	27 MHz	27 MHz	27 MHz
1	27 MHz	27 MHz	27.027 MHz

Pin Configurations

Figure 1. CY24212, 8-pin SOIC

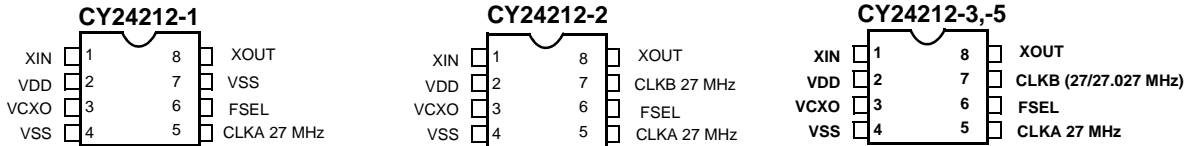

Table 3. Pin Definition

Name	Pin Number	Description
XIN	1	Reference Input.
VDD	2	Voltage Supply.
VCXO	3	Input Analog Control for VCXO.
VSS	4	Ground.
CLKA	5	27-MHz Clock Output.
FSEL (-1,-2)	6	Input Frequency Select, Weak Internal Pull up. FSEL = 0, XIN = 13.5 MHz FSEL = 1, XIN = 27 MHz
FSEL (-3,-5)	6	Output Frequency Select, Weak Internal Pull up. FSEL = 0, CLKA = 27 MHz, CLKB = 27 MHz FSEL = 1, CLKA = 27 MHz, CLKB = 27.027 MHz
VSS (-1)	7	Ground.
CLKB (-2)	7	27 MHz.
CLKB (-3,-5)	7	27 MHz/27.027 MHz.
XOUT ^[1]	8	Reference Output.

Pullable Crystal Specifications

Parameter	Name	Min	Typ.	Max	Unit
CR _{load}	Crystal Load Capacitance		14		pF
C0/C1				240	
ESR	Equivalent Series Resistance		35	50	Ω
T _o	Operating Temperature	0		70	°C
Crystal Accuracy	Crystal Accuracy			± 20	ppm
TT _s	Stability over Temperature and Aging			± 50	ppm

Absolute Maximum Conditions

Parameter	Description	Min	Max	Unit
V _{DD}	Supply Voltage	-0.5	7.0	V
T _S	Storage Temperature ^[2]	-65	125	°C
T _J	Junction Temperature		125	°C
	Digital Inputs	V _{SS} - 0.3	V _{DD} + 0.3	V
	Electrostatic Discharge	2		kV

Recommended Operating Conditions

Parameter	Description	Min	Typ.	Max	Unit
V _{DD}	Operating Voltage	3.135	3.3	3.465	V
T _A	Ambient Temperature	0		70	°C
C _{LOAD}	Max. Load Capacitance			15	pF
f _{REF}	Reference Frequency	13.5		27	MHz

Notes

1. Float XOUT if XIN is externally driven.
2. Rated for ten years.

DC Electrical Specifications

Parameter	Name	Description	Min	Typ	Max	Unit
I _{OH}	Output High Current	V _{OH} = V _{DD} - 0.5, V _{DD} = 3.3V (source)	12	24		mA
I _{OL}	Output Low Current	V _{OL} = 0.5, V _{DD} = 3.3V (sink)	12	24		mA
C _{IN}	Input Capacitance				7	pF
I _{IH}	Input High Current	V _{IH} = V _{DD}	-	5	10	μA
I _{IL}	Input Low Current	V _{IL} = 0V	-	-	50	μA
f _{ΔXO}	VCXO Pullability Range		±150			ppm
V _{VCXO}	VCXO Input Range		0		V _{DD}	V
I _{DD}	Supply Current	Sum of Core and Output Current			35	mA
V _{IH}	Input High Voltage	CMOS levels, 70% of V _{DD}	0.7			V _{DD}
V _{IL}	Input Low Voltage	CMOS levels, 30% of V _{DD}			0.3	V _{DD}
R _{UP}	Pull up resistor on inputs	V _{DD} = 3.14 to 3.47V, measured V _{IN} = 0V		100	150	kΩ

AC Electrical Specifications (V_{DD} = 3.3V)

Parameter ^[3]	Name	Description	Min	Typ	Max	Unit
DC	Output Duty Cycle	Duty Cycle is defined in <i>Figure 2</i> , 50% of V _{DD}	45	50	55	%
ER	Rising Edge Rate	Output Clock Edge Rate, Measured from 20% to 80% of V _{DD} , C _{LOAD} = 15 pF. See <i>Figure 3</i> .	0.8	1.4		V/ns
EF	Falling Edge Rate	Output Clock Edge Rate, Measured from 80% to 20% of V _{DD} , C _{LOAD} = 15 pF. See <i>Figure 3</i> .	0.8	1.4		V/ns
t ₉	Clock Jitter	Peak-to-peak period jitter		300		ps
t ₁₀	PLL Lock Time				3	ms

Test and Measurement Setup

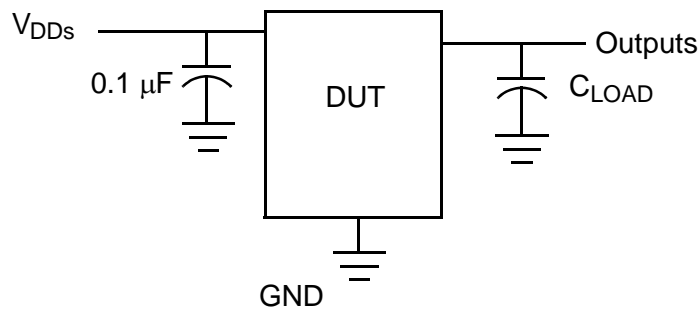

Note
3. Not 100% tested.

Voltage and Timing Definitions

Figure 2. Duty Cycle Definition

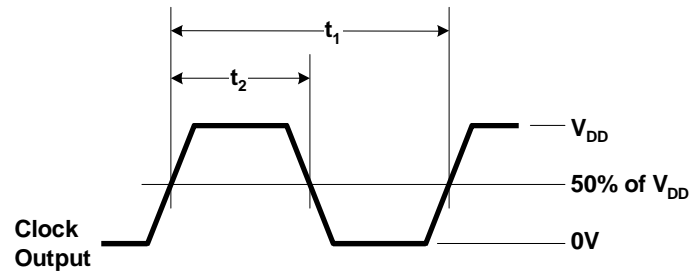
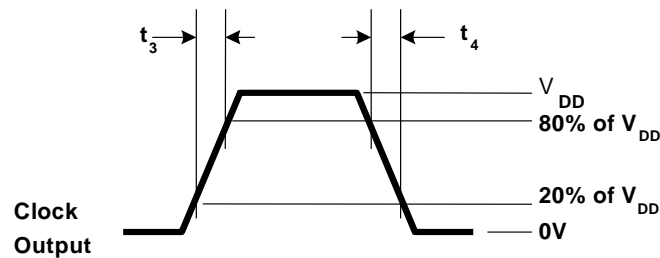

Figure 3. $ER = (0.6 \times V_{DD}) / t_3$, $EF = (0.6 \times V_{DD}) / t_4$



Ordering Information

Ordering Code	Package Name	Package Type	Operating Range	Operating Voltage
CY24212SC-1 ^[4]	S8	8-Pin SOIC	Commercial	3.3V
CY24212SC-1T ^[4]	S8	8-Pin SOIC -Tape and Reel	Commercial	3.3V
CY24212SC-2 ^[4]	S8	8-Pin SOIC	Commercial	3.3V
CY24212SC-2T ^[4]	S8	8-Pin SOIC -Tape and Reel	Commercial	3.3V
CY24212SC-3 ^[4]	S8	8-Pin SOIC	Commercial	3.3V
CY24212SC-3T ^[4]	S8	8-Pin SOIC -Tape and Reel	Commercial	3.3V
CY24212SC-5 ^[4]	S8	8-Pin SOIC	Commercial	3.3V
CY24212SC-5T ^[4]	S8	8-Pin SOIC -Tape and Reel	Commercial	3.3V
Pb-free				
CY24212SXC-5 ^[4]	S8	8-Pin SOIC	Commercial	3.3V
CY24212SXC-5T ^[4]	S8	8-Pin SOIC -Tape and Reel	Commercial	3.3V
CY24212KSXC-5	S8	8-Pin SOIC	Commercial	3.3V

Note

4. Not recommended for new designs.

Package Drawing and Dimensions

Figure 4. 8-lead (150-Mil) SOIC S8

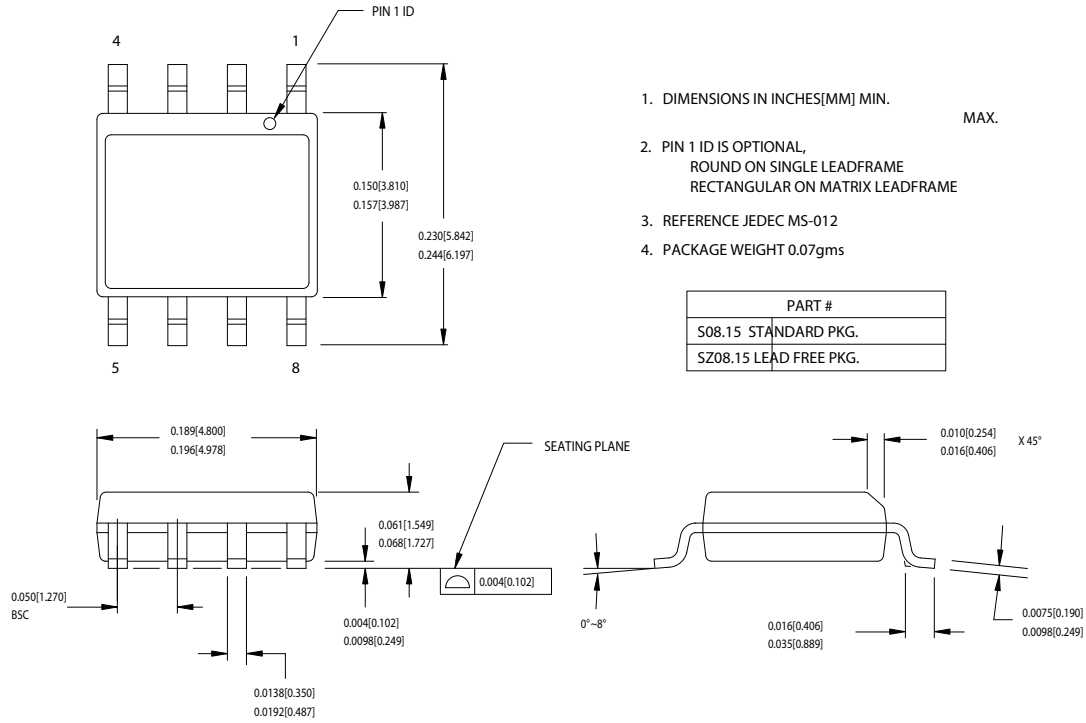

51-85066-°C

Document History Page

Document Title: CY24212 MediaClock™ MPEG Clock Generator with VCXO Document Number: 38-07402				
REV.	ECN NO.	Issue Date	Orig. of Change	Description of Change
**	117089	09/09/02	CKN	New Data Sheet
*A	120888	12/06/02	CKN	Added -3
*B	123064	02/19/03	CKN	Added -5
*C	345540	See ECN	RGL	Added Pb-free for -5 part
*D	2447126	See ECN	AESA	Updated template. Added Note "Not recommended for new designs." Added part number CY24212KSXC-5 in ordering information table.

© Cypress Semiconductor Corporation, 2002-2008. The information contained herein is subject to change without notice. Cypress Semiconductor Corporation assumes no responsibility for the use of any circuitry other than circuitry embodied in a Cypress product. Nor does it convey or imply any license under patent or other rights. Cypress products are not warranted nor intended to be used for medical, life support, life saving, critical control or safety applications, unless pursuant to an express written agreement with Cypress. Furthermore, Cypress does not authorize its products for use as critical components in life-support systems where a malfunction or failure may reasonably be expected to result in significant injury to the user. The inclusion of Cypress products in life-support systems application implies that the manufacturer assumes all risk of such use and in doing so indemnifies Cypress against all charges.

Any Source Code (software and/or firmware) is owned by Cypress Semiconductor Corporation (Cypress) and is protected by and subject to worldwide patent protection (United States and foreign), United States copyright laws and international treaty provisions. Cypress hereby grants to licensee a personal, non-exclusive, non-transferable license to copy, use, modify, create derivative works of, and compile the Cypress Source Code and derivative works for the sole purpose of creating custom software and or firmware in support of licensee product to be used only in conjunction with a Cypress integrated circuit as specified in the applicable agreement. Any reproduction, modification, translation, compilation, or representation of this Source Code except as specified above is prohibited without the express written permission of Cypress.

Disclaimer: CYPRESS MAKES NO WARRANTY OF ANY KIND, EXPRESS OR IMPLIED, WITH REGARD TO THIS MATERIAL, INCLUDING, BUT NOT LIMITED TO, THE IMPLIED WARRANTIES OF MERCHANTABILITY AND FITNESS FOR A PARTICULAR PURPOSE. Cypress reserves the right to make changes without further notice to the materials described herein. Cypress does not assume any liability arising out of the application or use of any product or circuit described herein. Cypress does not authorize its products for use as critical components in life-support systems where a malfunction or failure may reasonably be expected to result in significant injury to the user. The inclusion of Cypress' product in a life-support systems application implies that the manufacturer assumes all risk of such use and in doing so indemnifies Cypress against all charges.

Use may be limited by and subject to the applicable Cypress software license agreement.